

Article Arrival Date

19.02.2021

Article Type

Research Article

Article Published Date

20.03.2022

Doi Number: <http://dx.doi.org/10.38063/ejons.627>**USING MQTT PROTOCOL TO CONTROL THE COMBI BOILERS OF OPENTHERM COMPATIBLE****Erçin TEOMAN**

Electrical-Electronics Engineer, Dokuz Eylul University, The Graduate School of Natural and Applied Sciences, Department of Mechatronics Engineering, Izmir, Turkey, ORCID:0000-0002-0488-104X

Özlem AKKAN

Assistant Professor, Dokuz Eylul University, Izmir Vocational School, Electronics and Automation Department, Izmir, Turkey, ORCID:0000-0003-1781-6375

ABSTRACT

Since the first years of humanity, heating still maintains its place as one of the most basic needs for home comfort. In future, we have to create communication network that will enable heating systems to work more efficiently and comfortably. Combi boiler is a device used both for heating domestic water and for heating needs. The OpenTherm Protocol was created by combi boiler manufacturers. This protocol provides the opportunity to control combi boiler from different brands using the same communication language. When wireless communication is required, frequently, we see that the OpenTherm protocol is used as RF, but there are too many breaks in this setup. It is not possible to fully communicate with the heating area. System that installed over a Wi-Fi with TCP/IP based MQTT will be better than RF. MQTT is a communication protocol frequently used about used in IOT applications. MQTT is a protocol that uses TCP/IP infrastructure and can meet all our communication needs for OpenTherm without any problems.

Keywords: MQTT, OpenTherm, IoT, TCP/IP, Combi Boiler.

312

1. INTRODUCTION

This article provides information about how the application works and the components that make up the system. RF communication which used in smart home application operating at 868 MHz cannot be said to be good at breaking through walls. Room temperatures are not detected correctly when communication is lost. Since MQTT is a protocol built on TCP/IP structure, it will work with a frequency of around 2.4 GHz. It will connect to the internet with the Wi-Fi modem at home and will stay in constant communication with the cloud system. In order to install an effective smart home heating system, it is necessary to place RF transmitters at many points in the house, but these transmitters will have problems. Instead, they can broadcast continuously using the MQTT protocol, so all data is collected by the broker without any data loss. The combi boiler software written by the combi boiler manufacturers either stops or works at a certain level when no command is sent to it. A 24KW combi boiler, which consumes 10 m³ of natural gas per day due to RF communication interruption, can reach up to 14 m³. If the combi also stops working when the data flow stops, then the user will face the cooling of his house. These disconnections will not occur after communication with MQTT. MQTT can communicate over long distances without disconnection. In each room thermostat, an MQTT broadcaster can transmit temperature data and even additional information such as humidity data to the cloud. Effective use of MQTT is required on the basic of smart home application. The subscriber system on the combi boiler

side will wait for the next broadcast with the MQTT protocol. This system will convert the incoming information to OpenTherm and will be physically connected to the boiler with 2 cables. On the master side, there is a room thermostat and a wifi transmitter that will send via MQTT protocol. This part constitutes the publisher side of the system. Support of the MQTT broadcaster structure, we can call the sensors that output with the MQTT protocol in different parts of the house as broadcasters. All broadcasting sensors transmit data to the broker. The subscriber station will receive the data from the broker and share this data. A connection can be established between the subscriber and the mobile application to control the system. In the second part of the article, we will mention concepts such as the internet of things, smart home applications, Message Queue Telemetry Transport, radio frequencies, and the working types of combi boilers. At the end of the section, information will be given about the electronic components to be used in the experiment. In the experiment section, which is the fourth part of the article, we will give information about how the experiment is done and what is used. The last part of the article will be the conclusion. We will mention our post-experiment results here.

2. MATERIAL AND METHODS

In this section, we will benefit from the concepts of the internet of things and, accordingly, smart home applications. At this point, MQTT draws our roadmap. The radio frequency used in such household uses is mentioned. (Erdoğan, H. , Küçük, K. & Khan, S. A., 2020). The methods used in the control of the combi boilers and the electronic components and software that will enable us to do the research experimentally are explained.

2.1 Internet of Things – IoT

The use of IOT in the industry is increasing day by day and it has become an indispensable concept for smart home systems. All kinds of objects, which could not even transfer any data before, started to communicate with their surroundings with this concept. With this revolution, where all objects are now talking to each other, IOT smart home systems have allowed different items in the house to communicate in harmony with each other. MQTT protocol has also taken its place as the most frequently used protocol in IoT. (Gultunca, C. & Zaim, A. H., 2018).

313

2.2 Smart Home Application

Smart home applications are a concept that deals with lighting, heating, cooling, security and many similar applications with a single control mechanism. This system can be controlled from the panels in the house as well as from the smart phones of the users. It is possible to connect electrical appliances, television and other units to this system. With different sensors and triggers, every device connected to the smart home system can be activated or deactivated. Devices used in heating systems have different communication languages, so it is difficult for smart home systems to control these devices. (Yalçınkaya, F. , Aydılek, H. , Erten, M. Y. & İnanç, N., 2020).

2.3 Message Queue Telemetry Transport – MQTT

Today, we know that the most important protocol of the inter working is TCP/IP. MQTT is a perfect messaging protocol that also meets today's requirements for IoT and M2M applications. In other words, it allows small electronic devices to network and talk among themselves. We can network and communicate between our sensor stations and our electronic circuits, but since these are expensive, very power-consuming and non-overlapping technologies for IoT, M2M-style applications, similar alternative systems and protocols have been developed today. For example, ZigBee, 6LowPAN etc. They are similar structures to MQTT, but they have become popular because of their features such as working on TCP/IP, not requiring much data consumption, safe operation in environments with poor communication conditions, and frequently heard terms such as IoT and M2M. (International Organization for Standardization, 2016)

2.3.1 The Publisher And The Subscriber

The MQTT protocol has two main structures in the network: a broker and a lot of clients. The broker is actually a server which handles all messages from some clients and get routing all messages to destination clients. MQTT messages always are organized by topics, the network designer has the flexibility to specify which goal clients can interact with goal certain messages. All communication between the publisher and the subscriber takes place bidirectionally over the broker as in figure - 1. (EMQ, 2022)

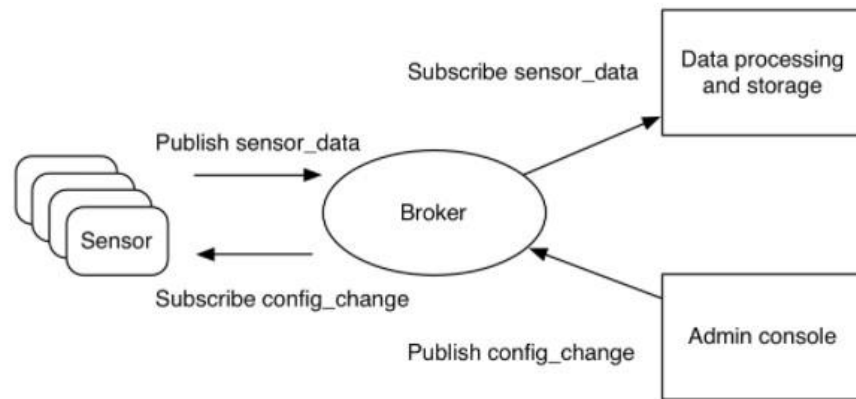

Figure 1 - The MQTT Publisher And Subscriber Structure [3]

2.3.2 Public MQTT Servers

The broker is the area where data is collected in the cloud. There are sites that provide this cloud space, but also permanent cloud space can be purchased for commercial projects. For example, you can set up your MQTT server using the mosquitto software. (Mosquitto, 2022). There are open source domains called Mosca and EMQ. We need to use some code to generate MQTT messages and subscribe to our broadcasting sensor modules. Codes as shown in figure-2 are used to communicate with the server cloud. (EMQ, 2022)

314

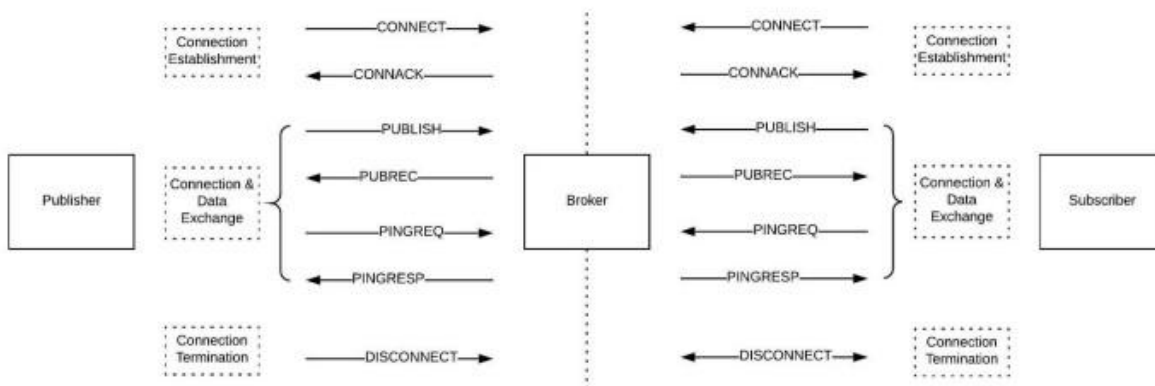

Figure 2 - The MQTT Message Structure [3]

2.4 Radio Frequency – RF

Radio frequency (RF) is the oscillation rate of any system in the frequency range of 20 kHz to 300 GHz, although the ranges vary according to the areas of use. It covers an area above the human voice and below the infrared frequencies. Especially in some protocols operating at frequencies between 300 MHz and 3 GHz, it is difficult to determine the security and accuracy of data transfer as much as TCP/IP. (Karaca,O & Sokullu,R., 2012). It is a radio frequency that can be compatible with all home systems and the implementation of TCP/IP MQTT Protocol around 2.4 GHz. Especially in European countries, frequencies between 863 and 870 MHz are used with short range devices. Many manufacturers prefer this frequency range because it does not require a license. Combi boiler manufacturers or companies that produce room thermostats for combi boilers frequently use this band in their products.

2.5 Working Models Of Combi Boilers

Combi boilers can be controlled in different languages and methods while running. The three most commonly used methods are listed below.

2.5.1 On/Off

All combi boiler devices are suitable to work with the structure called on/off, but this operation ensures that the combi is working and shutting down at the values set on the combi boiler. Even in different brands, an on/off room control can turn almost any combi boiler on and off. It is the most primitive control method since it cannot change the temperature of the combi and does not provide full control. For example, when the room control set to 23 degrees reaches the target, it turns off the combi boiler with the relay. When the temperature drops to 21 or 22 degrees, the relay switches the contact and starts the combi boiler again. It is not possible to control the flame in the heat exchanger, so on/off room thermostats are also called non-modulation.

2.5.2 Brand Based Language

Each brand develops special software and language to work only with their own combi boilers. While some combi boiler manufacturer uses a language called eBus in its products, the other uses a language called EMS. Produced combi boilers and room thermostats can only work together if they are of the same brand.

2.5.3 OpenTherm Protocol

In conventional heating controls “heating on” or “heating off” is the only control that a thermostat designer has available to control the heating system, it’s either “full” or “full off”. OpenTherm designers now have a method to instruct the boiler directly with how much heat is required to maintain the correct room setpoint. The specification has only one mandatory control command which requests the boiler to control the boiler setpoint or heating output to a value between 0°C and 100°C. It is not required that the boiler can actually achieve the desired boiler setpoint, it may be that the boiler has a maximum setting of 80°C. It is also likely that the boiler has a minimum boiler setpoint in which case the boiler may switch off if the desired setpoint is too low. In all these cases the OpenTherm specification has ID codes which allow designers to interrogate the individual OpenTherm appliance with its capabilities and then decide just how the control should operate. There are over a 100 different OpenTherm commands or requests for information that are available to the designer to use when defining a heating control system. (OpenTherm Association, 2022). The opentherm connection is shown in figure-3 with code B.

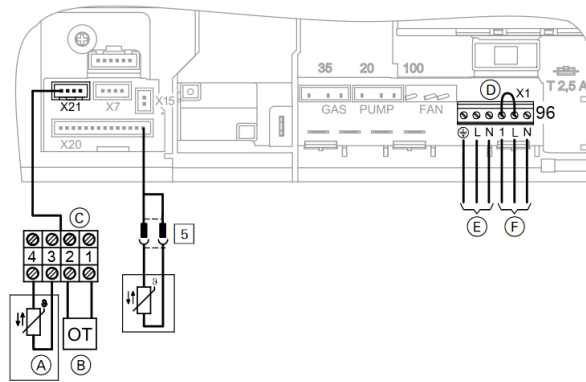

Figure – 3 : Viessmann Vitodens 100 - “B” Shows OpenTherm Connection [12]

2.6 Electronic Components of System

This section introduces all the electronic equipment necessary for the experiment to take place.

2.6.1 Microcontroller Based Evaluation Board – Arduino Nano 33

It is one of the smallest development boards that has a wifi module on it. Figure - 4 shows the top view of the card.(Arduino, 2022)



Figure – 4 : Arduino Nano 33 Evaluation Board [1]

316

2.6.2 NodeMCU with ESP8266

It is a development board with ESP8266 WiFi module loaded with NodeMCU firmware. The following figure-5 shows its. Since it is developed using the ESP8266 SDK, it does not need an extra microcontroller. (Nodemcu, 2022)



Figure – 5 : NodeMCU Board [8]

2.6.3 OpenTherm Shield

In order to make the opentherm protocol understandable, we need to use these modules just before the boiler OT connection. Shows in figure-6. (Diyless Electronics, 2020)

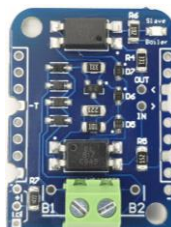

Figure – 6 : OpenTherm Shield [2]

2.6.4 Temperature Sensors

LM75 is a basic temperature sensor which is sense between $-55\text{ }^{\circ}\text{C}$ and $125\text{ }^{\circ}\text{C}$. Figure-7 is shows it. It called as linear temperature sensor. (Texas Instruments, 2022)

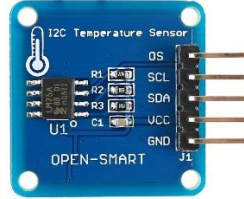

Figure – 7 : LM75 Temperature Sensor. [11]

2.6.5 Power Supply

The adapter that converts from AC 220 to DC 12V, which is necessary to give the required power to the each module.

3. EXPERIMENT

The temperature is detected in each room with the LM75 sensor. All of the temperature information from the rooms is published from the ESP8266 module of the nodeMCU. This information is stored almost losslessly in the cloud environment. In this way, even if the data flow to the cloud stops, the main unit of the arduino nano 33 can subscribe to the last uploaded data via the broker cloud. Experiment shows in Figure – 8. Even if these data are outdated, we can use them for a while with the software. The average room temperature is determined by taking the arithmetic average of the two data transferred from the rooms to the cloud. It runs an algorithm again by looking at the data coming to the subscriber main unit and the outside temperature data it has learned over the internet and transfers this data to the opentherm shield. Opentherm shield transfers this data to the opentherm input of the combi boiler via cable. Especially in systems using 868 MHz and similar radio frequencies, the data sent may be corrupted or may not reach at all, since there is no subscriber structure. Thanks to the cloud, we ensure that the boiler receives data continuously with the MQTT protocol.

317

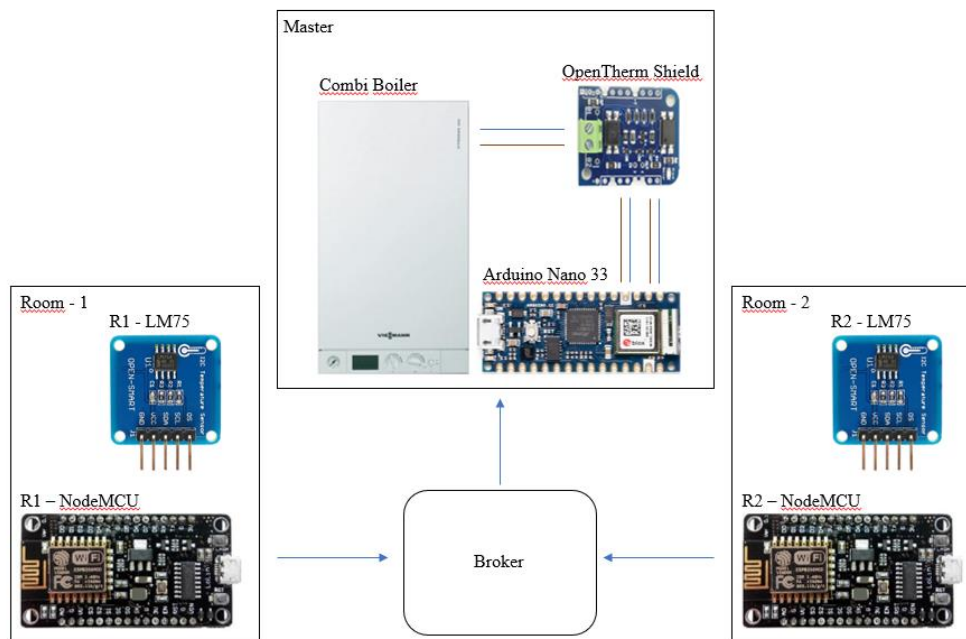

Figure – 8 : Experiment Basic Schema.

4. CONCLUSION

When we use OpenTherm, it is possible to use almost all combi boilers with modulation, regardless of brand. More than one publisher can be added to the system. With the information coming from different points, the device Works as much as it needs. After two days experiment , the combi boiler followed the temperature in room without any communication error fast and it worked perfectly.

A 24kW combi boiler consumes about $2,6m^3$ natural gas at %100 working. In case of RF failure, either the house will cool completely or it will continue with a constant consumption of $1,3m^3$ for per hour. On the other hand, opentherm remained connected, it would work modulated. Thus, it will turn off when there is no need or it will consume at the level of quarter when there is less need. Since it is connected to Opentherm, it will work as much as it needs and if it wants, it will be able to run the combi boiler with 15% performance. As the communication between the sensors and the cloud is continuously ensured in smart home applications, a reduction in natural gas consumption has been achieved. In future works, energy optimization will be studied by adding sensors such as humidity, presence detection, apart from the temperature sensor.

5. REFERENCES

- [1] Arduino (2022). *Arduino nano 33 ble*. <https://store.arduino.cc/products/arduino-nano-33-ble>
- [2] Diyleless Electronics (2020). *Master opentherm shield*. <https://diyleless.com/product/master-opentherm-shield>
- [3] Emq (2017). *The massively scalable mqtt broker for iot and mobile applications*. <http://emqtt.io>
- [4] Erdoğan, H. , Küçük, K. & Khan, S. A. (2020). Endüstriyel iot bulut uygulamaları için düşük maliyetli modbus/mqtt ağ geçidi tasarımı ve gerçekleştirilmesi . *Bilecik Şeyh Edebali Üniversitesi Fen Bilimleri Dergisi* , 7 (1) , 170-183 . DOI: 10.35193/bseufbd.708445
- [5] Gultunca, C. & Zaim, A. H. (2018). Examination and comparison of the communication protocols on the application layer in iot. *İstanbul Ticaret Üniversitesi Fen Bilimleri Dergisi* , 17 (33) , 41-50 . Retrieved from <https://dergipark.org.tr/tr/pub/ticaretfbid/issue/55952/391807>
- [6] International Organization for Standardization (2016). *Information technology - message queuing telemetry transport (mqtt) v3.1.1*. <https://www.iso.org/standard/69466.html>
- [7] Mosquitto (2022). *Eclipse iot and edge developer survey results*. <https://mosquitto.org/>
- [8] Nodemcu (2022). *Nodemcu*. https://www.nodemcu.com/index_en.html
- [9] OpenTherm Association (2022). *What is opentherm*. <https://www.opentherm.eu/opentherm-protocol/what-is-opentherm/>
- [10] Karaca, O & Sokullu, R. (2012). A cross-layer fault tolerance management module for wireless sensor networks. *Journal of Zhejiang University-Science C*, 13(9). DOI: 10.1631/jzus.C1200029
- [11] Texas Instruments (2022). *LM75A digital temperature sensor and thermal watchdog with two-wire interface datasheet (rev. p)*. <https://www.ti.com/product/LM75A>
- [12] Viessmann (2022). *Viessmann vitodens 100W installation and service instructions*. <https://viessmann.ca>
- [13] Yalçınkaya, F. , Aydılek, H. , Erten, M. Y. & İnanç, N. (2020). IoT based Smart Home Testbed using MQTT Communication Protocol . *International Journal of Engineering Research and Development* , 12 (1) , 317-324 . DOI:10.29137/umagd.654056